



Operator's Manual and Spare Parts



FLAIL MOWER MODEL - EF/EFG/FL/FLP SERIES

Rev.00

CONGRATULATION

Dear Customer,

With the decision to buy a TIGER AGRI MACHINERY, you have made a wise choice. You will immediately note the ruggedness and dependability of this machine. This manual contains information on operation and maintenance of the machine. Observing all advice will guarantee a regular working order a longer machine life and savings on machine maintenance. To avoid injuries and to get the best results from your machine, read it carefully and keep it around for future reference.

TIGER AGRI MACHINERY is always at your disposal to give you quick and efficient assistance to maintain the correct operation and maximum output of this machine.

With best Wishes

TIGER AGRI MACHINERY

Disclaimer :

TIGER AGRI MACHINERY reserves the right to alter the machine without prior notice and without immediately updating this manual. The flail mower is designed exclusively for working the soil. Failure to use this machine other than as described in this manual could result in human injury and / or equipment damage and / or equipment damage. TIGER AGRI MACHINERY declines any responsibility for damage or injury caused by, directly or indirectly, from breakage of the machine or parts thereof, as well as those caused by proper or improper use of the same.

INDEX

1	Introduction	
	1.1) Identifying the machine.....	4
	1.2) Technical Specification of Flail mower	5
2	How to work Safety and prevent accidents	6
	1) Recognize Safety Information.....	6
	2.2) Understand Signal.....	6
	2.3) Follow GENERAL WORK AREA Safety It.....	7
	2.4) Follow GENERAL personal Safety Instruction.....	8
	2.5) Follow GENERAL FUEL Safety Instructions.....	9
	2.6) Follow EQUIPMENT USE AND CARE Instructions.....	9
	2.7) Follow MAINTENANCE Safety Instructions.....	10
	2.8) Follow STORAGE Safety Instructions.....	10
3	Flail Mower Setup	11
4	Tractor Flail mower Setup	13
5	Attaching and Detaching of Machine to tractor	15
	5.1) Lower Linkage positioning.....	15
	5.2) Connecting to the tractor.....	15
	5.3) PTO Shaft Installation.....	16
	5.4) Begin work.....	18
	5.4.1) Adjusting the Height.....	19
	5.4.2) Regulating the Tension of Driving Belt.....	19
	5.4.3) Starting up.....	21
	5.5) Stopping and Disconnection.....	22
	5.6) Transporting.....	22
	5.7) Parking.....	22
6	Maintenance	24
	6.1) Recommended Lubrication.....	24
	- GEAR BOX LUBRICATION.....	24
	- BEARING HOUSE LUBRICATION.....	25
	- PROPELLER SHAFT MAINTANANCE.....	25
	6.2) Blade Replacement.....	26
	6.3) Routine Maintenance.....	26
	6.3.1) 8 Hours or Daily Maintenance	27
	6.3.2) Season Maintenance.....	27
	6.3.3) Annual Maintenance.....	27
7	Troubleshooting and Solutions	29
8	Torque Table	31
9	Parts Identification with Code	32
10	Warranty	40

SECTION – 1 INTRODUCTION

TIGER AGRI MACHINERY welcomes you to the growing family of new product owners. The flail mower is a machine which has been designed for mulching grass and small bracken and shall be used in the indicated purpose.

The flail mower consist of a rotating shaft with many blades attached to it. The blades cut the grass while travelling over the working area. Rotational power to the shaft is provided by the tractor PTO shaft through the gear box in the center of the machine. The flail mower attaches to the 3 point hitch on the tractor.

The standard machine is equipped as follows:

- Depth Skid Plate (RH + LH)
- PTO shaft and relative instruction manual
- Spanner









1.1 Identifying the machine

There is identifying registration plate fixed on the machine (fig.1).This plate gives you the following information.







- Manufacturers' name
- Standard Weight
- Model
- Year of Manufacturing
- Batch Number

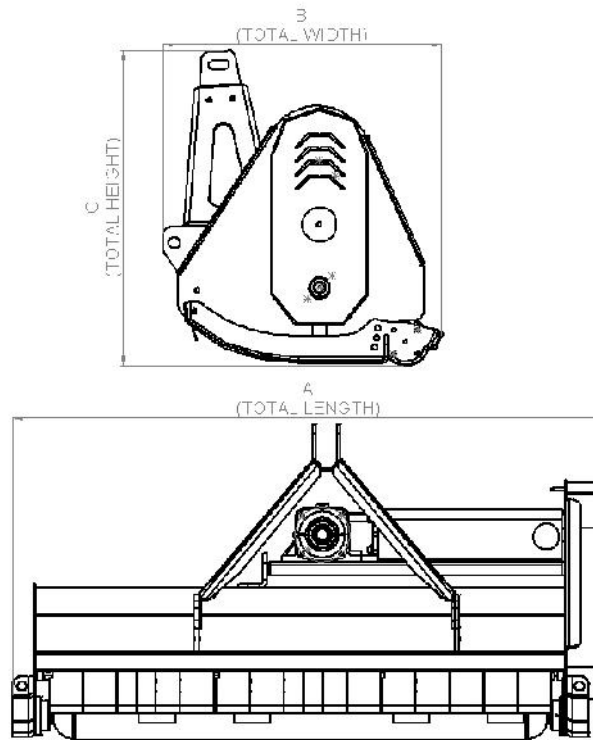

1.2 Technical Specification of FLAIL MOWER







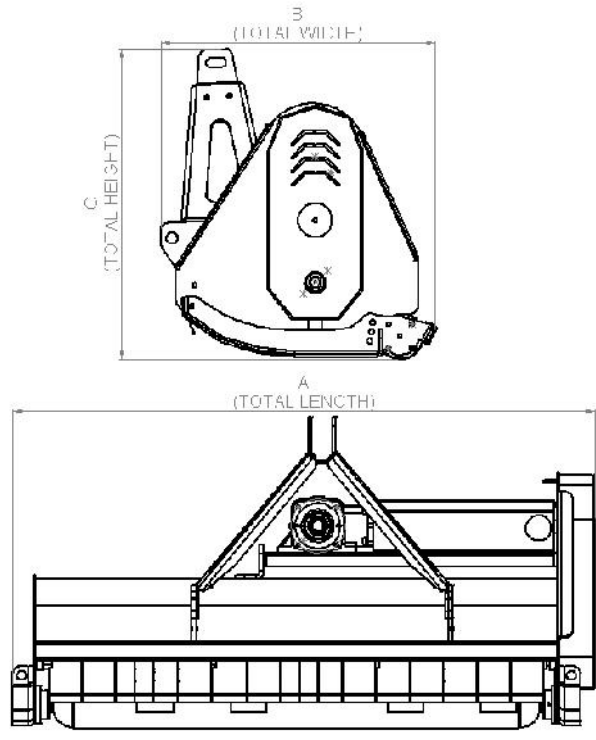

MODEL								
EF85	V-Belt 2x A Sec	950 mm 37 Inch	820 Mm 32 Inch	14-18 Hp 10-13 Kw	100 Kg 221 Lbs	Y	30	Cat I
EF95	V-Belt 2x A Sec	1050 mm 42 Inch	920 Mm 36 Inch	16-20 Hp 12-15 Kw	115 Kg 254 Lbs	Y	36	Cat I
EF105	V-Belt 2x A Sec	1150 mm 45 Inch	1020 Mm 40 Inch	20-30 Hp 15-22 Kw	130 Kg 287 Lbs	Y	36	Cat I
EF115	V-Belt 2x A Sec	1250 mm 49 Inch	1120 Mm 44 Inch	20-30 Hp 15-22 Kw	145 Kg 320 Lbs	Y	42	Cat I
EF125	V-Belt 2x A Sec	1350 mm 53 Inch	1220 mm 48 Inch	25-35 Hp 19-26 kw	160 Kg 353 Lbs	Y	42	Cat I
EF135	V-Belt 2x A Sec	1450 mm 57 Inch	1320 mm 52 Inch	25-35 Hp 19-26 kw	175 Kg 386 Lbs	Y	48	Cat I
EF145	V-Belt 2x A Sec	1550 mm 61 Inch	1420 mm 56 Inch	25-35 Hp 19-26 kw	190 Kg 419 Lbs	Y	48	Cat I
EF155	V-Belt 2x A Sec	1650 mm 65 Inch	1520 mm 60 Inch	30-40 Hp 22-30 kw	210 Kg 463 Lbs	Y	54	Cat I
EF165	V-Belt 2x A Sec	1750 mm 69 Inch	1620 mm 64 Inch	30-40 Hp 22-30 kw	235 Kg 518 Lbs	Y	54	Cat I
EF175	V-Belt 2x A Sec	1850 mm 73 Inch	1720 mm 68 Inch	30-40 Hp 22-30 kw	255 Kg 562 Lbs	Y	60	Cat I
		(A)						









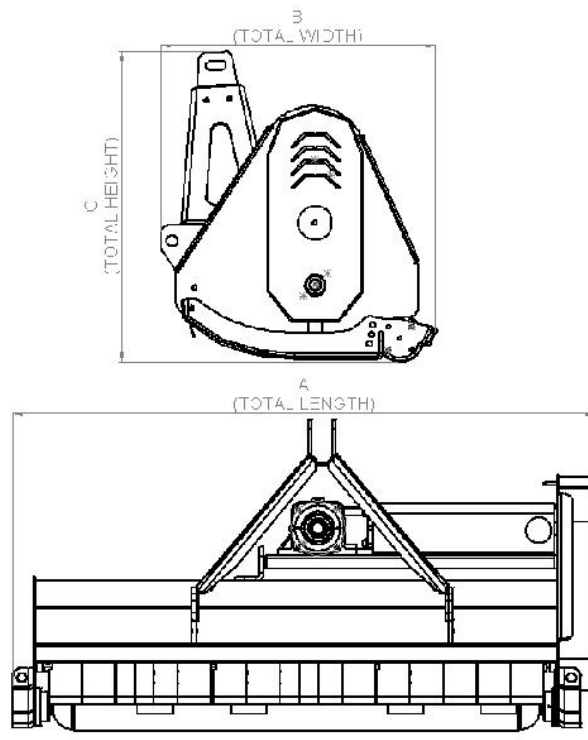

MODEL								
EFG105	V-Belt 2xA Sec	1150 mm 45 Inch	1020 MM 40 Inch	18-28 HP Kw	225 Kg 497 Lbs	Forged Hammer	16	Cat I
EFG115	V-Belt 2xA Sec	1250 mm 49 Inch	1120 Mm 44 Inch	20-30 Hp Kw	245 Kg 542 Lbs	Forged Hammer	20	Cat I
EFG125	V-Belt 2xA Sec	1350 mm 53 Inch	1220 Mm 48 Inch	20-35 Hp Kw	255 Kg 564 Lbs	Forged Hammer	20	Cat I
EFG135	V-Belt 3xA Sec	1450 mm 57 Inch	1320 Mm 52 Inch	25-35 Hp Kw	270 Kg 597 Lbs	Forged Hammer	24	Cat I
EFG145	V-Belt 3xA Sec	1550 mm 61 Inch	1420 mm 56 inch	25-35 Hp Kw	285 Kg 630 Lbs	Forged Hammer	24	Cat I
EFG155	V-Belt 3xA Sec	1650 mm 67 Inch	1520 mm 60 Inch	30-40 Hp Kw	300 Kg 663 Lbs	Forged Hammer	24	Cat I
EFG165	V-Belt 3xA Sec	1750 mm 69 Inch	1620 mm 64 Inch	35-45 Hp Kw	315 Kg 696 Lbs	Forged Hammer	28	Cat I
EFG175	V-Belt 3xA Sec	1850 mm 73 Inch	1720 mm 68 Inch	35-55 Hp Kw	330 Kg 729 Lbs	Forged Hammer	28	Cat I
EFG195	V-Belt 3xA Sec	2090 mm 82 Inch	1960 mm 77 Inch	35-60 Hp Kw	360 Kg 796 Lbs	Forged Hammer	32	Cat I

(A)

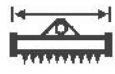

MODEL								
FL110	V-Belt 2xA Sec	1230 mm 48 Inch	1100 MM 43 Inch	20-30 Hp 15-22 Kw	165 Kg 364 Lbs	Forged Hammer	16	Cat I
FL130	V-Belt 2xA Sec	1430 mm 56 Inch	1300 Mm 51 Inch	25-35 Hp 19-26 Kw	180 Kg 397 Lbs	Forged Hammer	18	Cat I
FL150	V-Belt 2xA Sec	1630 mm 64 Inch	1500 Mm 59 Inch	30-40 Hp 22-30 Kw	200 Kg 441 Lbs	Forged Hammer	20	Cat I
FL170	V-Belt 2xA Sec	1830 mm 72 Inch	1700 Mm 66 Inch	30-40 Hp 22-30 Kw	220 Kg 485 Lbs	Forged Hammer	22	Cat I
		(A)						



MODEL								
FLP110	V-Belt 2xA Sec	1230 mm 48 Inch	1100 mm 43 Inch	20-30 Hp 15-22 Kw	175 Kg 386 Lbs	Forged Hammer	16	Cat I
FLP130	V-Belt 2xA Sec	1430 mm 56 Inch	1300 Mm 51 Inch	25-35Hp 19-26 Kw	190 Kg 419 Lbs	Forged Hammer	18	Cat I
FLP150	V-Belt 2xA Sec	1630 mm 64 Inch	1500 Mm 59 Inch	30-40 Hp 22-30 Kw	210 Kg 463 Lbs	Forged Hammer	20	Cat I
FLP170	V-Belt 2xA Sec	1830 mm 72 Inch	1700 Mm 67 Inch	30-40 Hp 22-30 Kw	230 Kg 507 Lbs	Forged Hammer	22	Cat I

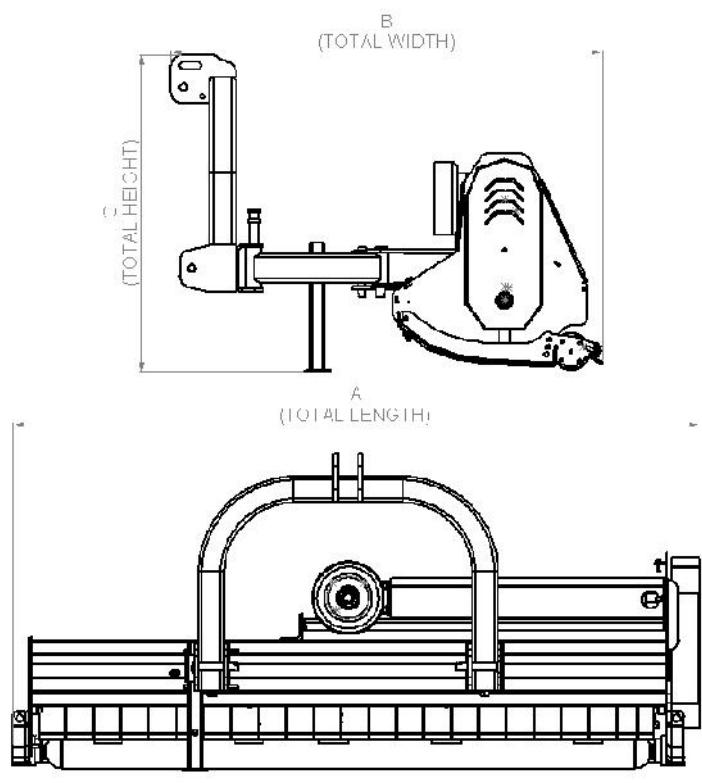

SECTION - 2 HOW TO WORK SAFETY AND PREVENT ACCIDENTS

Safety is a primary concern in the design and manufacturing of our products. Unfortunately, our efforts to provide safe equipment can be wiped out by a single careless act of an operator.

In addition to the design and configuration of equipment, hazard control and accident prevention are dependent upon the awareness, concern, prudence and proper training of personnel involved in the operation, transport, maintenance and storage of equipment.

It has been said, "The best safety device is an informed, careful operator." We ask you to be that kind of operator.

2.1 Recognize Safety Information



This is a safety-alert symbol. A careful reading of this manual will allow you to understand this new piece of equipment and will provide you all the tools needed to use it safely.

Proper maintenance and knowledge of the safety rules of use will ensure the best performance and extend the life of the machine.

Follow recommended and safe operating practices.

2.2 Understand Signal

Safety alert symbol is used in conjunction with following Signal words, according to the degree of possible injuries that may result operating the implement;

	DANGER identifies the most serious hazards, if not avoided, will result in death or serious injury.
	WARNING indicates a potentially hazardous situation that, if not avoided, could result in death or serious injury, and includes hazards that are exposed when guards are removed. It may also be used to alert against unsafe practices.
	CAUTION indicates a potentially hazardous situation that, if not avoided, may result in minor or moderate injury. It may also be used to alert against unsafe practices.
	IMPORTANT indicates instruction or procedure that, if not observed, can cause damage to equipment or environment.
	NOTE indicates helpful information.

READ – UNDERSTAND – FOLLOW, the safety messages following the Safety Alert symbol and Signal Words. Failure to comply with safety messages could result in serious bodily injury or death.

IMPORTANT – Handle the equipment safely and carefully

BEFORE USE – If you are not familiar with the safe operation/handling of the equipment, or are in any way unsure of any aspect of suitability or correct use it for you application, you should complete training conducted by a person or organization qualified in safe use and operation of this equipment, including fuel/electrical handling and safety.

WARNINGS

- Read all safety warnings and all instructions. When using the equipment, basic safety precautions detailed here must always be followed to reduce the risk of fire, electric shock, personal injury and material damage.
- Do not operate the equipment in flammable or explosive environments, such as in the presence of flammable liquids, gases or dust. The equipment may create sparks or heat that may ignite vapors, dust etc.
- Keep clear of moving parts.
- Equipment may be a potential source of electric shock or injury if misused.
- Do not operate the equipment if it is damaged, malfunctioning or is in an excessively worn state.
- Do not allow others to use the equipment unless they have read this manual and are adequately trained.

2.3 Follow GENERALWORK AREA Safety Instructions



ONLY operate the log splitter from the operator zone as shown below. The operator has the safest and most efficient access to the control valve and the beam in this location. Failure to operate the log splitter in this position can result in serious injury or death



Work areas should be clean and well lit.



Do not operate the equipment if bystanders, animals etc are within operating range of the equipment or the general work area.



Be sure that all safety pictograms are legible. If pictograms are worn, they be replaced with others obtained from the Manufacturer and placed in the position indicated by this manual.



Before using the machine, make sure that all safety devices are

installed and in good working conditions. In case of damages of shields of shields, replace them immediately.



Is forbidden to remove or alter safety devices.



Before starting and during operation of the implement make sure there are no people or animals in the area of operation: the machine can project material from the back, with risks of serious injury or death.



Pay maximum attention to avoid any accidental contact with rotating or moving parts of the machine.



During operation, adjustment, maintenance, repairing or transportation of the machine, the operator must always use appropriate Personal Protective Equipment (PPE)



Do not operate the implement while wearing loose-fitting clothing that can give rise to entanglement in parts of the machine.



Do not operate the implement when tired, not in good condition or under the influence of alcohol or drugs.



If the use of the machine is required at night or in conditions of reduced visibility, use the lighting system of the tractor and possibly an auxiliary lighting system.

2.4 Follow GENERAL Personal Safety Instructions



Keep packaging away from children – risk of suffocation!



Operators must use the equipment correctly. When using the equipment, consider conditions and pay due care to persons and property.



Prevent unintentional starting of the equipment – ensure equipment and power source switches are in the OFF position before connecting or moving the equipment.



Do not carry equipment with hands/fingers touching any controls.



Remove any tools or other items that are not a part of the equipment from it before starting or switching on.



Stay alert and use common sense when operating equipment. Do not over reach. Always maintain secure footing and balance.



Do not use the equipment if tired or under the influence of drugs, alcohol or medication.



This equipment is not intended for use by persons with reduced physical, sensory or mental capabilities.

2.5 Follow GENERAL FUEL Safety Instructions



Petrol/fuel/gasoline is extremely flammable – Keep clear of naked flames or other ignition sources.



Do not spill fuel. If you spill fuel, wipe it off the equipment immediately – if fuel gets on your clothing, change clothing.



Do NOT smoke near fuel or when refuelling.



Always shut of the engine before refuelling.



Do NOT refuel a hot engine.



Open the fuel cap carefully to allow any pressure build-up in the tank to release slowly.



Always refuel in well ventilated areas.



Always check for fuel leakage. If fuel leakage is found, do not start or run the engine until all leaks are fixed.

2.6 Follow EQUIPMENT USE AND CARE Safety Instructions



The equipment is designed for domestic use only.



Handle the equipment safely and carefully.



Before use, inspect the equipment for misalignment or binding of moving parts, loose components, damage or any other condition that may affect its operation. If damaged have the equipment repaired by an authorised service centre or technician before use.



Prevent unintentional starting of the equipment – ensure equipment and power switched are in the OFF position before connecting or moving equipment. Do not carry equipment with hands or fingers touching any controls. Remove any tools or other items that are not a part of the equipment from it before starting or switching on.



Do not force the equipment. Use the correct equipment for your application. Equipment will perform better and be safer when used within its design and usage parameters.



Use the equipment and accessories etc. in accordance with these instructions, considering working conditions and the work to be performed. Using the equipment for operations different from those intended could result in hazardous situations.



Always keep equipment components (engines, hoses, handles, controls, frames, housing, guards etc) and accessories (cutting tools, nozzles, bits etc) properly maintained. Keep the equipment clean and, where applicable, properly lubricated.



Store the equipment out of reach of children or untrained persons. To avoid burns or fire hazards, let the equipment cool completely before transporting or storing. Never place or store the equipment near flammable materials, combustible gases or liquids etc.



The equipment is not weather-proof, and should not be stored in direct sunlight, at high ambient temperatures or locations that are damped or humid.



Do NOT clean equipment with solvents, flammable liquids or harsh abrasives.



For specific equipment safety use and care, see Equipment Safety.

2.7 Follow MAINTENANCE Safety Instructions



All maintenance and repair operations must be performed by qualified and trained operators, with the tractor engine off; the PTO disengaged, the lowered to the ground or on security stands, the ignition key off and the parking brake set.



Perform repairs and replacements part should only be original spare parts provided by the manufacturer, importer or your dealer.



Perform maintenance operations using appropriate Personal Protective Equipment (protective eyeglasses, har hat, hearing protection, safety shoes, overall and work gloves, filter mask).



Before any maintenance operation, make sure that the parts which become hot during use (friction clutch, gearbox etc.) have cooled.



Do not perform repairs that you do not know. Always follow the manual instructions and in case of doubt contact the Manufacturer or your dealer.



Do not swallow fuels or lubricants. In case of accidental contact with eyes, rinse well with water and consult a doctor.

2.8 Follow STORAGE Safety Instructions



Never leave the tractor unattended with the implement in the lifted position. Accidental operation of lifting lever or a hydraulic failure may cause a sudden drop in the unit which result in injury or death.



Following the operation, or before unhooking the implement, stop the tractor, set the brakes, disengage the PTO, lower the attached implement to the ground, shut off the engine, remove the ignition key and wait for all moving parts to stop.



Make sure all parked machines are on a hard, level surface and engage all safety devices.



Place support blocks under implement as needed to prevent the unit from tipping over onto a child and/or an adult. An implement that tips over can result in injury or death.









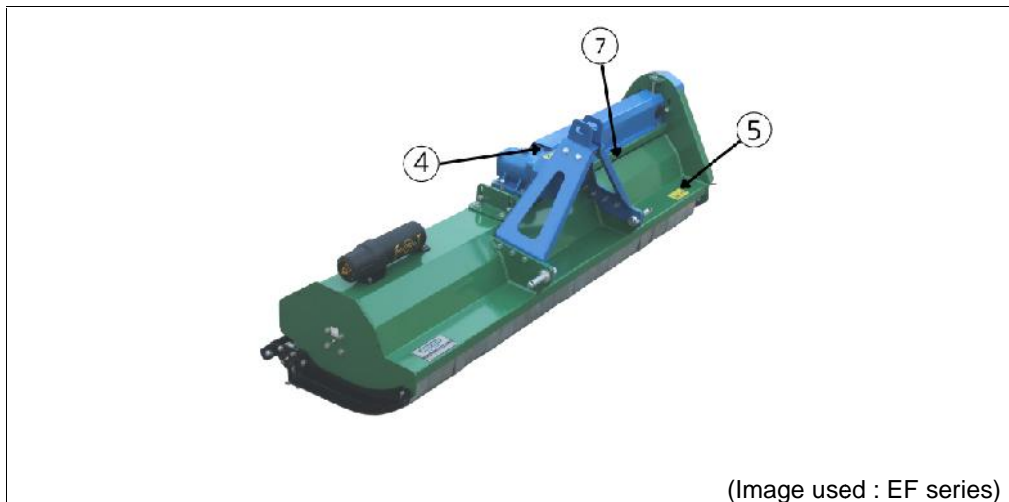
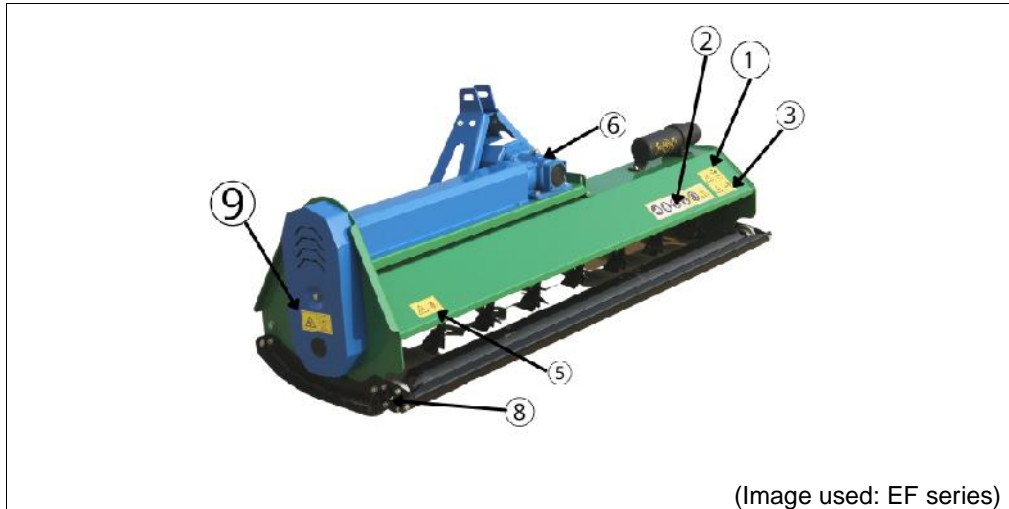

Store the unit in an area away from human activity.

2.9 Safety Labels

The following safety labels are posted on the machine. Read them carefully and memorize their meanings. Always replace them if they are detached or damaged taking care of putting them as indicated fig.7

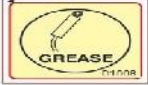

1		<p>Disengage the PTO, turn OFF the tractor engine, remove the key and ensure that all rotating parts have stopped before approaching the implement. Read the operator's manual before performing any maintenance operation. Thrown or flying objects hazard.</p>
2		<p>Safety Equipment</p>
3		<p>Crushing hazards & Thrown or Flying objects hazards.</p>
4		<p>Operate only with 540 rpm PTO</p>
5		<p>Rotating Gears</p>
6		<p>Oil filling point</p>
7		<p>Lifting point</p>
8		<p>Grease filling point</p>
9		<p>Hand Hazard</p>

SECTION – 3 FLAIL MOWER SET UP

Preparing the machine for work must be done with the PTO disengaged the machine on the ground and tractor OFF and blocked.

Before starting the machine, the SETUP includes following inspection at machine level:

- Check the Flail Mower is suited to the tractor horsepower.
- Check oil and grease lubrication point as per Manufacturer's requirement for relevant machine.
- Guards are properly installed and all parts subject to wear and tear are in good working condition.
- Safety decals are on the machine and clean.
- Bolts and nuts are tightened.

SECTION – 4 TRACTOR SETUP

4.1 Use your Tractor Operator's Manual

- Always refer to your Tractor Operator's Manual for specific detailed information regarding operation of your tractor.
- Following tractor related information uses tractors to illustrate preparation, attachment and operational procedures.
- Use your tractor OM for detailed information, as procedures will vary by equipment.

4.2 Tractor Stability and Lifting Capacity Check

When machine is jointed to tractor, It becomes an integral part of it. Attached equipment's weight is closely related with road position and stability of tractor. In normal conditions, it is assumed that 20% of tractor weight is carried by front axle. In this case, attached equipment's weight should not be greater than 30% of tractor weight. This factor can be summarized in following formulas:

$$M \times s \leq 0,2 \times T \times i + Z \times (d + i)$$

$$Z \geq \frac{(M \times s) - (0,2 \times T \times i)}{(d + i)}$$

$$M \leq 0,3 \times T$$

Symbol	Unit	Description
M	kg	Mass weighing on arms of hoist with full load
T	kg	Mass of tractor
Z	kg	Total mass of ballast
i	m	Tractor wheelbase that is horizontal distance between axles of tractor
d	m	Horizontal distance between centre of gravity of ballast and front of axle of tractor
s	m	Horizontal distance between centre gravity of operating machine and rear axle of tractor

When machine is attached to tractor, front weights should put through above mentioned formula. These weights should be calculated according to capacity of tractor's lifting weight and packing.

SECTION – 5 ATTACHING AND DETACHING TO THE TRACTOR

The implement is delivered fully assembled and equipped with a driveshaft with shear bolt and related operating manual.

When the machine is delivered, check that there is no damage to the implement and driveshaft. In case of damage or missing parts immediately notify the manufacturer, importer or your dealer.



5.1 Lower Linkage Positioning

The EF-EFG-FL-FLP Series fail mowers are designed to be mounted on tractors equipped with :

- 3-point Hitch Category I (ISO 730 standard);

5.2 Connecting to the Tractor

Implement can be attached to the suitable category tractor. Follow below procedure for attaching the implement to the tractor.

	<ul style="list-style-type: none">• Disengage PTO Drive• Trained person is required to attach and detach from the tractor. Else may cause major injury to operator and severe damage to implement and tractor.
	<ul style="list-style-type: none">• Implement should always be park on level ground for attaching and detaching to tractor safely and easily.• Before attaching implement to the tractor, check for any accessories fitted on tractor like drawbar, swinging drawbar, automatic hitch etc. for any hindrance, restriction, proper functioning and free up and movement of equipment. If required remove accessories before attaching equipment.

1. Be certain that the tractor drawbar will not interfere. Move drawbar ahead or remove if required. The drawbar should also be checked for clearance when the unit is raising for the first time.
2. Align lower link arms of the tractor to hitch clevises on the mower. Insert lower hitch pins into lower ball swivels and attach link pins.
3. Attach tractor top link to upper floating hitch on mower with pin supplied. Secure with lock pin.

- Adjust tractor top link in or out to place upper hitch pin vertically above or slightly behind lower hitch pins to allow mower flotation. The mower should be running with the back 15 degrees lower than the front.

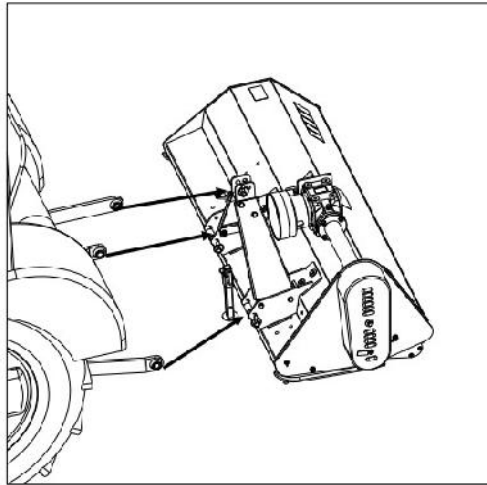

(Image : EF Series)

5.3 PTO Shaft Installation

IMPORTANT	The universal propeller shaft supplied, with the machine, is of standard length. Therefore it might be necessary to adapt the universal drive shaft
------------------	---

IMPORTANT	<ul style="list-style-type: none"> • The propeller shaft must have protective covers. • The propeller shaft without covers should never be used. • The tractor may not be running during the mounting and dismounting of the shaft. • No other persons should be around the propeller shaft during processes with the shaft.
------------------	--

Make sure the PTO shaft length is compatible with the different working positions of the implement. If the PTO shaft is too long it might bend and damage may occur to the tractor or implement.

Place the tractor and the implement on a flat surface. Attach the 3 point linkage of the tractor (see the section – 5.2 connecting to the tractors)

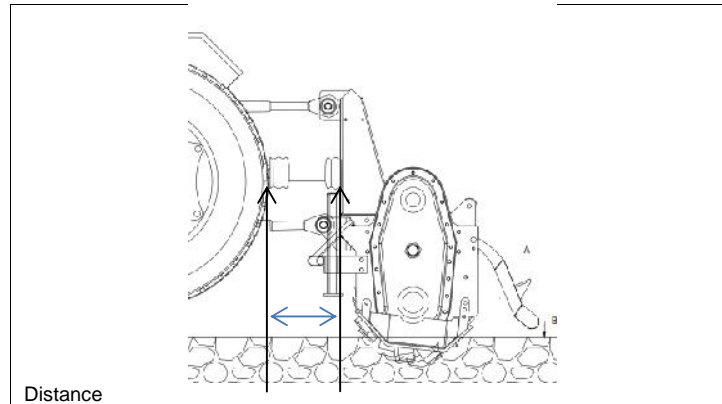

Find the length between the groove of PTO output on the tractor, and the PTO input on the implement when the implement and tractor is in horizontal position.

Before operating the implement ensure that the size of the propeller shaft is adequate. The PTO shaft supplied with the machine comes in a standard length. Therefore it may need to be shortened depending on your tractor and implement.

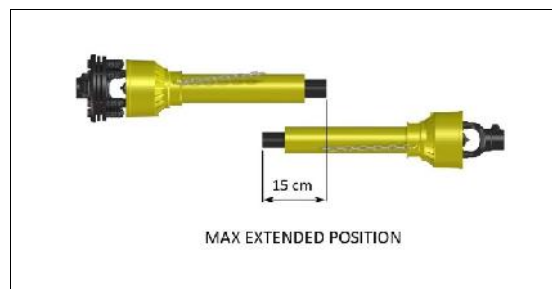

When the propeller shaft is at its minimum length, there must be at least a 4 cm of distance between the ends of each transmission tube and the yoke side.



When the propeller shaft is at maximum operational extension, there must be an overlap between the tubes profiles of 15 cm at least.

IMPORTANT	<ul style="list-style-type: none"> • Before operating the implement the first time, make sure that the propeller shaft is lubricated in accordance with how indicated in the instruction booklet. • Before operating the implement the first time, and after long periods of inactivity, make sure that the propeller shaft clutch has not seized. It may be
------------------	--

	<p>necessary to 'slip' the clutch and reset due to possible oxidation of the components that may compromise the correct slipping during the usage.</p> <ul style="list-style-type: none"> • Always engage the tractor PTO at low rpm to minimise the effect of the peak torque on the propeller shaft and the machine.
--	---

5.4 Begin work

Before the start-up and before each use, perform the following pre-operation inspections and service of the implement;

- Checks that the implement has no damaged functional parts and has all mechanical parts are good condition. Repair and / or replace the damage parts;
- Check that the implement has no missing parts (pins, safety pins, plug oil so on). Restore the missing parts;
- Check that all guards and safety devices have no damages and are properly positioned. Repair and / or replace the damaged shields, restore the correct position;
- Verify that the PTO driveshaft is properly installed (see section : connecting to the tractor);
- Check that the propeller shaft clutch is in good condition, and that its components are not subject to "sticking" (see section: Maintenance – Propeller shaft);
- Check the presence of lubricant in all greasing points of the implement (propeller shaft, supports so on) (see section : Maintenance / Propeller shaft and Maintenance / Support rotor);
- Check that blades are not excessively worn and the relating hardware is correctly tightened (see section : Maintenance)
- Check that all hardware (nuts, bolts etc.) are properly tightened. Refer to the tightening table in the manual for proper torque value;
- Check that all safety labels are correctly positioned, in good condition and legible. Replace any damaged labels;
- Check that there is no constraint that may prevent the movement of equipment. Remove any constraints.

Before the start-up and before each use, make the following checks on the operating area you intend to operate;

- Check that area is clear of foreign objects (rocks, branches or debris). Remove any obstacle and visibility highlight obstacles that cannot be removed (e.g., with flags);
- Make sure that in the area you intend operate there are no people or animals;
- Make sure the soil to be worked is not too sandy or rocky.

	<p>Before conducting the above inspections and service, make sure the tractor engine is OFF, all rotation parts are completely stopped, and the tractor is in park with the parking brake engaged. Make sure the implement is resting on the ground or securely blocked up and the tractor lifting hydraulics locked.</p>
---	--

Once all the checks above have been done, start the tractor and the implement as follows:

- Start the tractor and engage the tractor PTO at low rpm, making sure that the implement is NOT in the raised position but close to the ground, then increase speed engine until to 540 rpm;
- Lower the implement on the ground and simultaneously start driving the tractor forward at low speed. Subsequently, increase the ground speed depending on ground conditions;
- If the outside temperature is very cold, its recommended to engage the PTO and have the implement operate at low speed (with the tractor stationary) to warm oil and lubricate parts;
- Drive for a while operating the implement then stop the tractor to check the quality of the work performed. If you need to get off the tractor, lift the implement just out of the ground, reduce engine speed and disengage PTO, stop engine and remove the ignition key;

5.4.1 Adjusting the Height

In order to conduct a precise work, the machine shall be operated according to the recommended cutting height.

For saving fuel and power and reducing the wear of the machine, the cutting height must be regulated correctly.

When regulating the working height, loosen the screw (1), remove the screw (2) on both side. Regulate the roller height (see following drawings) fix the parts on the set position, the lowest hole is the highest working height. Put the screw (2) into the set hole, tighten the screw (1) and screw (2).

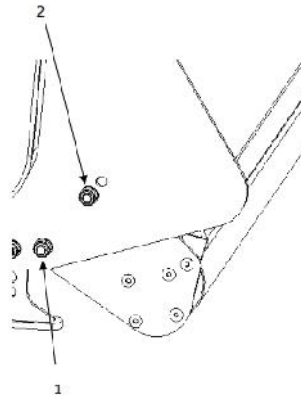

5.4.2 Regulating the Tension of Driving Belt

ATTENTION: The machine shall always stand properly for regulating the tension.

Remove the driving belt cover. Loosen screw 1, 2, 3 & 4 and adjust screw 1. Tighten the screw 1, 2, 3 & 4. Put back the driving belt cover.

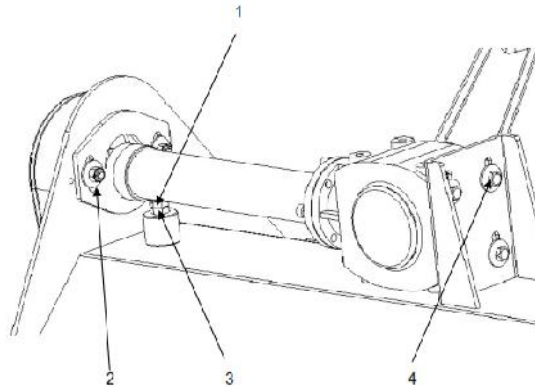

5.4.3 Starting up

Before starting the machine, control and adjust the following items;

- Tension of trapezoidal driving belt
- Oil level of gear
- Point of lubrication
- All bolts, nuts and screw

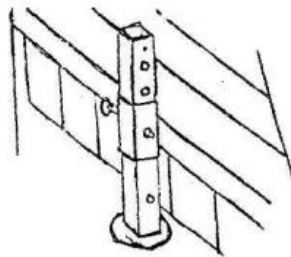

Not in operation

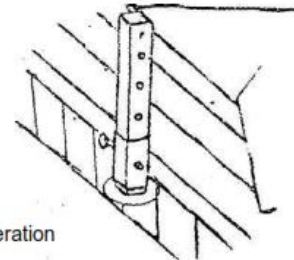

In operation

In order to keep machine stable, install the supporting frame on the machine when the machine is stopped (see above drawing)

ATTENTION: When transferring the moving state of the machine to the working state, do not stand between the machine and the tractor.

The machine coupling is equipped with 3 pins so that the machine can be coupled with all tractors with universal coupling with 3 pins. Each telescopic pole on the machine can be adjusted properly according to the type of the tractors. The universal joint shall be tense and the largest distance in the closed state shall be 5/10 cm.

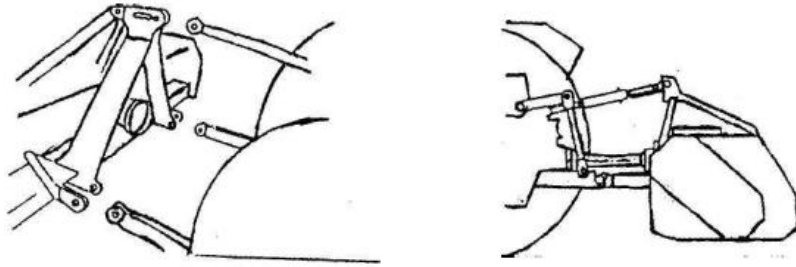

Moving the lifting arm and putting it between axes, insert the joint pins and fix them with pins. Fix the lifting arm with chain and tensioning device to prevent lateral movement of the machine. Connect the universal joint to the PTO shaft of the tractor on the side of the tractor. In any event, it cannot produce a collision in any position. While connecting 3 points, the PTO shaft of the tractor shall be parallel with the ground. It is very important to keep the machine driving axle and the PTO shaft of the tractor in Parallel.

The machine shall be lifted from the ground before moving the machine.

5.5 Stopping and Disconnection

To stop the implement at the end of a working session:

- Bring the tractor to a complete stop;
- Place the transmission in park or neutral;
- Reduce the engine speed, then disengage the PTO;
- Wait for stopping of all rotating parts;
- Lower the implement to the ground;
- Set the parking brake;
- Shut down the engine and remove the key before exiting the tractor;
- Do the cleaning and maintenance required to make the machine ready for later use (see Section – Maintenance)



Never leave the tractor unattended with the implement in the lifted position

To disconnect the implement from the tractor (e.g. to make a change of implement)

- Adjust the skids to their lowest position (see section – adjustments);
- Adjust the support stand to the lowest position, through the use of relative retaining pin;
- Park the tractor on a dry and level surface;
- Reduce the engine speed, then disengage PTO;
- Wait for stopping of all rotating parts with implement lowered to the ground;
- Set the parking brake;
- Shut down the engine and remove the key before exiting the tractor;

- Place safety blocks under implement to prevent the unit from tipping over onto a child and /or an adult. An implement that tips over can result in injury or death;
- Disconnect the driveline from the tractor PTO and rest it on the provided support of the implement;
- Disconnect the top link and rear lifting arms of the tractor from the implement hitches;
- Check the implement stability. If needed, place additional safety block;
- Get on the tractor, start the engine and move away from the implement slowly;
- Make sure the implement remains stored in a protected area; to prevent those unauthorised personnel can approach it.

If you do not intend to use your implement for a long period of time, (e.g., at the end of the season), do cleaning and maintenance operations as specified in Section – MAINTENANCE and STORAGE

5.6 Transporting

To set the implement for transportation, perform the following steps:

- Idle tractor engine, disengage tractor PTO, and wait for stopping of all rotating parts;
- Lift the implement far enough off the ground to clear any objects BUT not to a point where the PTO Shaft comes in contact with the tractor or implement. A minimum gap of 2 cm should be left between the tubes and tractor and (see also Section – PTO Shaft Installation)
- Lock the tractor lifting hydraulics, turn off the engine, set the parking brake, remove ignition key and get off the tractor;
- Adjust the support stand to the highest position, through the use of the retaining pin, to prevent its possible damage during transport.

When driving on public roads operators must strictly follow local laws and traffic regulations.



When driving on public road, reduce your speed, be aware of traffic around you and proceed in such a way that faster moving vehicles may pass you safely.

5.7 Parking

- The machine inside and outside shall be cleaned carefully so as to avoid corrosion.
- Don't spray water on the rolling bearing if you clean the machine with high pressure sprayer.
- Check and clean the universal joint, driving belt press roller or replace them if they are not in good state.
- Spread oil on all recommended parts.
- Recoat the parts rubbed and damaged for anti corrosion.
- Store the machine in a dry, level area. Support the frame with planks if required.

Before the machine is started up, check the following items regularly.

- Check oil level and add it if not enough.
- Check and tighten all screw and nuts.
- Check the regulated state of the machine.
- Check the blade state
- Check the air hole on the gearbox. If it is blocked, clean or open the hole with compressed air.
- Don't spread oil or grease on the driving belts. If there is oil or grease on the belts, wipe the belts, in case the belt sliding and wearing occur.

ATTENTION: Check the machine every 10 hours. Repair the damaged parts or replace the blade according to the manufacturer's recommendation, to keep the machine balancing.

Check all tightening parts and replace them if necessary.

Don't remove the protective parts on some points and protect the machine.

ATTENTION: in the case of vibration, stop the machine and check the blade. If the blade is broken or damaged, replace it with same type of blade. If the machine still vibrates then send the machine to authorized repairer.

SECTION – 6 MAINTENANCE

Proper and regular maintenance ensures a long life of the implement avoids failures and saves time and repair costs.

Periodic inspections and maintenance operations described in this section must be performed by the operator in the times and terms prescribed. Failure to comply with maintenance prescriptions can compromise the functioning and duration of the machine, and consequently invalidate the warranty.

The frequency of maintenance indicated refers to normal conditions of use: it must be intensified in severe operating conditions (frequent stops and starts, prolonged winter season, etc)

Repairs, maintenance, and modifications other than those mentioned in this paragraph should NOT be performed without consulting the manufacturer or your dealer. Manufacturer, as the case, may give the authorisation to proceed with the repair together with all necessary instructions.

Wrong or inappropriate repairs or maintenance may generate abnormal operating conditions, equipment damage and generate risks for the operator.

 WARNING	For safety reasons, all maintenance operations must be performed with tractor PTO disengaged, implement stopped and completely lowered to the ground or onto support blocks, parking brake set, tractor engine shut off, and ignition key removed.
IMPORTANT	Respect the environment. Store or dispose of unused chemicals as specified by the chemical manufacturer.

6.1 Recommended Lubrication

The various maintenance instructions are listed below. Doing these maintenance jobs at regular intervals will not only lengthen the machine life but also reduce its maintenance costs substantially.

GEAR BOX LUBRICATION

Lubricant : SAE EP 80W90 Gear Oil

Check the oil level every 50 hours, making sure the oil mark left on the dipstick of the filling plug (top of the gearbox) is located between the two reference marks (minimum and maximum).

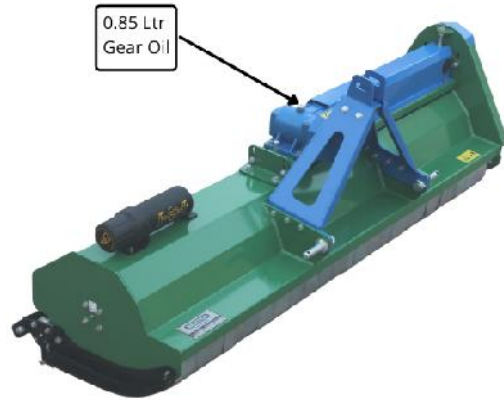

If the oil is below the minimum, fill up to restore the correct level and oil change must be performed:

- After the first 50 working hours;
- Each 500 working hours;

BERAING HOUSE LUBRICATION

Lubricant: SAE multi-purpose lithium-type grease OR oil.

Grease the rotor hub support every eight (8) working, through a suitable grease gun or lubricating oil.



IMPORTANT	<p>Make sure you clean the grease nipple before using a grease gun.</p> <p>Do not let excess grease collect on or around these parts especially when operating in sandy areas.</p>
------------------	--

PROPELLER SHAFT MAINTENANCE

Lubricant: SAE Multi-purpose lithium-type grease
 Grease crosses, sliding parts of protective shielding and driveshaft transmission tubes.

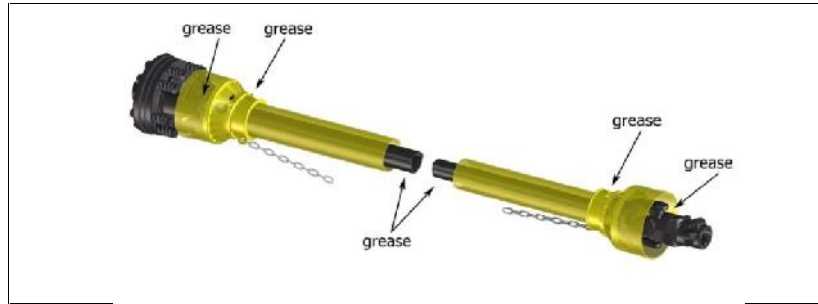

IMPORTANT	For details about maintenance and lubrication of the propeller shaft, refer to the user manual of the propeller shaft manufacturer.
------------------	---

6.2 Blade Replacement

Frequently check the wear condition of blades through visual inspection. The wear of blades is very variable depending on the type of soil.

Replacement of the blades is necessary when the operator notices increase of power absorption during operation or when the blade dimension is significantly reduced compared to the original.

The use of the machine with blades in bad condition compromises the quality of work.

Before performing replacement of the blades:

- Idle tractor engine, set the parking brake, disengage tractor PTO, and wait for all moving parts to come to a complete stop;
- Slightly raise the implement from the ground or place on safety blocks or mechanical stands;
- Lock the height control level of tractor's hydraulics;
- Turn off the tractor and remove the key.

To perform the replacement of blades:

- Remove the two bolts and washers clamping the blade to the rotor flange, then remove the blade;
- Position the new blade exactly where the worn blade was, then tighten the bolts, referring to the tightening table of this manual for proper torque values. Be sure to install the blade with cutting edge in front of the direction of rotation;
- Repeat the same procedure for all the other blades.

6.3 Routine Maintenance

By following a careful service and maintenance program for your machine, you will enjoy many years of trouble free operation.

The period recommended is based on normal operating conditions. Severe or unusual conditions may require more frequent maintenance.

6.3.1 8 HOURS OR DAILY MAINTANANCE

- Check and screw all nuts and bolts in connection parts.
- Check the blade and fixing parts everyday and replace the damaged parts if they are found damaged. Don't install damaged, worn and unbalanced blade. New sleeve shall be used to replace the worn fixing parts on the blade.

NOTE: The operator shall put on gloves and use suitable tools before changing blade.

- Check the oil in gearbox. Fill up to line if it's necessary.
- Grease bearing with a grease gun.
- Clean the implement; take away all grease and mud.

IMPORTANT: Check the oil level only when the unit is cold and the machine is level.

6.3.2 SEASON MAINTANANCE

Check the machine as below beside the terms of daily maintenance.

- Check the oil in gearbox; replace it if it is bad.
- Check the bearings of the blade spindles as mud and water may have entered, if the oil seals are damaged disassemble and clean and replace if it is necessary. Grease bearings.
- Check the distance between bearings and gears. Adjust them if it's necessary.

6.3.3 ANNUAL MAINTANANCE

- Clean mud and grease on the machine thoroughly.
- Check all clearance between bearings and gears if you have replaced them. Run it without load for 3-5 minutes.
- Check and clean blade axles. Replace oil seal and press grease into them.
- Check all blades, replace them if they are worn or damaged.
- Repair the skids and replace damaged or broken skids if required.
- Remove the driving shaft from the machine. Pull the machine driving shaft apart. Check and replace any components that are damaged or worn. Install the driveline on the machine. The driving shaft should telescope easily and the guard turns freely in the shaft.
- Let the oil in gearbox drain out thoroughly. Check and clean it. Fill new gear oil up to the dedicated oil level.

The oil shall be drained out after first 50 hours of operation time. Then the oil shall be drained off every 250 hours or one time every year.

The draining procedure is as follows: remove the draining bolt under the gear box, so that the oil drains. After the oil is completely drained, put back the bolt and fill the gear oil up to the dedicated level.

ATTENTION: Don't forget to disconnect the generator cable and batteries when welding on the machine, while the machine is coupled with the tractor.

SECTION – 7 TROUBLE SHOOTING and SOLUTIONS

PROBLEM	CAUSE	SOLUTIONS
Gearbox/transmission case noise noticeable and constant	Low oil level. Worn gears.	Add oil to the gearbox/transmission case. Replace gears
Noise and/or Excessive vibration from the implement	Knives blades worn or damaged. Bearings damaged. The front of the implement is not levelled to the back. Rotor damaged. Side V-Belt is damaged. Pulley and their grooves stuck with other debris.	Replace blades. Replace bearings. Adjust 3-point top link of tractor making implement PTO parallel to the ground. Repair/replace rotor Replace drive belt. Remove pulley cover & clean debris from belt areas & grooves.
Driveline vibration	Worn driveshaft. Machine lifted too high. Debris wrapped on the rotor.	Replace driveshaft. Lower machine and readjust tractor lift stop. Remove debris.
Rotor stops turning	Side V-Belt is slipping or burnt.	Replace new V-Belts
Smoke and/or hot smell from the implement	Debris wrapped around in blades and/or rotor. Low oil level in the gearbox. Side Gear V-Belt is burning	Remove debris. Add oil Adjust tighter for the V-Belts
Gearbox overheating	Low oil level.	Add oil.
Belt slipping	Excessive materials stuck between deck and rotor. Pulley grooves are wrapped with excessive other materials. Belts are damaged.	Unplug and clean mower deck. Remove pulley cover and clean grooves. Replace belts.
Patches of uncut grass	Mower at full throttle (540 PTO rpm). High speed gears are used. Belts are loosed and slipped during the operation. Knives blades are missing.	Check PTO speed and tractor engine. Shift transmission to a lower gear. Tighten the belts. Replace missing knives.
Oil leaking from gearbox/transmission case	Gearbox/transmission case Overfilled. Loose filling/drain plug.	Drain to the proper level. Tighten filling/drain plug.

	Damaged breather plug.	Replace breather plug.
	Damaged seals.	Replace seals.
Knives scalping grass	Cutting height is too low. Mowing pattern is not proper. Turning speed is high.	Raise cutting height by tractor draw bar. Change moving pattern. Reduce speed turns.
Uneven cut	High speed of rotor. Level of mower is not correct. Knives blades are missing.	Shift to a lower gear Level mower at optimum position for mowing. Replace knives blade.
Tractor loaded down by mower.	Mowing throttle at low speed. High speed gears are use. Debris stuck between deck and mower rotor.	Mow at full throttle (540 RPM) Shift to a lower gear. Clean Mower.

SECTION - 8 TORQUE TABLE

Check frequently hardware to make sure that screws and bolts are tightened according to torque values listed in the following table:

BOLT SIZE (METRIC)	8.8 grade		10.9 grade	
	N m	Ft lb	N m	Ft lb
M6	11	8	15	11
M8	26	19	36	27
M10	52	39	72	53
M12	91	67	125	93
M14	145	105	200	150
M16	225	165	315	230
M18	310	230	405	300
M20	440	325	610	450

SECTION - 9 PARTS IDENTIFICATION WITH CODE

FLAIL MOWER MAIN ASSEMBLY (EF SERIES)

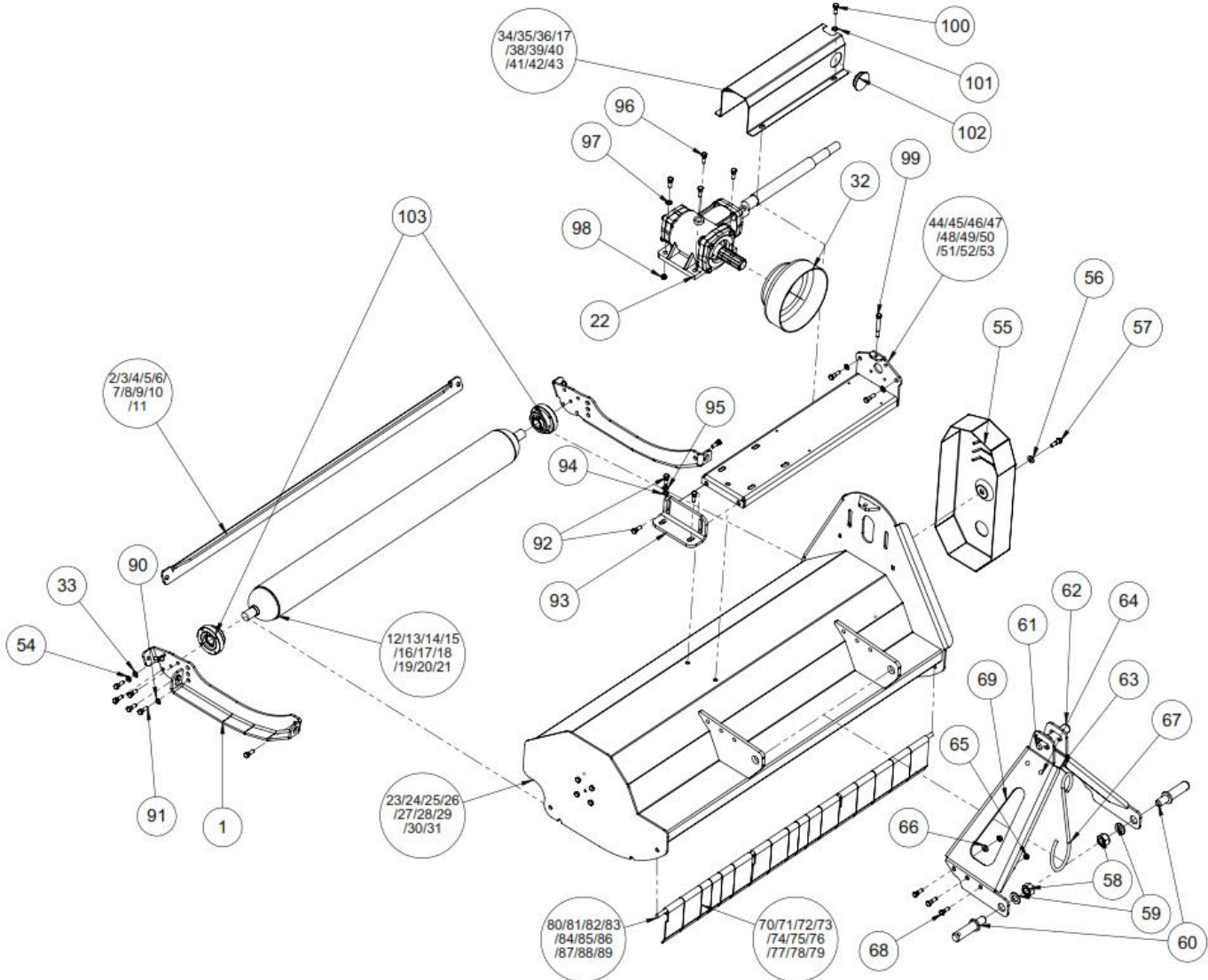

Item	Part Number	Qty	Part Name
1	21010001	6	Hex Bolt M8 x 1.25 x 25
2	21010002	1	Scraper (EF85)
3	21010003	1	Scraper (EF95)
4	21010004	1	Scraper (EF105)
5	21010005	1	Scraper (EF115)
6	21010006	1	Scraper (EF125)
7	21010007	1	Scraper (EF135)
8	21010008	1	Scraper (EF145)
9	21010009	1	Scraper (EF155)
10	21010010	1	Scraper (EF165)
11	21010011	1	Scraper (EF175)
12	21010012	1	Back roller (EF85)

13	21010013	1	Back Roller (EF95)
14	21010014	1	Back Roller (EF105)
15	21010015	1	Back Roller (EF115)
16	21010016	1	Back Roller (EF125)
17	21010017	1	Back Roller (EF135)
18	21010018	1	Back Roller (EF145)
19	21010019	1	Back Roller (EF155)
20	21010020	1	Back Roller (EF165)
21	21010021	1	Back Roller (EF175)
22	21010022	1	Gear Box Housing Complete (Without Jackshaft)
23	21010023	1	Main Frame (EF85)
24	21010024	1	Main Frame (EF95)
25	21010025	1	Main Frame (EF105)
26	21010026	1	Main Frame (EF115)
27	21010027	1	Main Frame (EF125)
28	21010028	1	Main Frame (EF135)
29	21010029	1	Main Frame (EF145)
30	21010030	1	Main Frame (EF155)
31	21010031	1	Main Frame (EF165)
32	21010032	1	Main Frame (EF175)
33	21010033	12	Plain Washer M8
34	21010034	1	Jack Shaft cover (EF85)
35	21010035	1	Jack Shaft Cover (EF95)
36	21010036	1	Jack Shaft cover (EF105)
37	21010037	1	Jack shaft cover (EF115)
38	21010038	1	Jack Shaft cover (EF125)
39	21010039	1	Jack shaft cover (EF135)
40	21010040	1	Jack shaft cover (EF145)
41	21010041	1	Jack shaft cover (EF155)
42	21010042	1	Jack shaft cover (EF165)
43	21010043	1	Jack shaft cover (EF175)
44	21010044	1	Jack shaft Weld Plate (EF85)
45	21010045	1	Jack Shaft weld plate (EF95)
46	21010046	1	Jack Shaft weld plate (EF105)
47	21010047	1	Jack shaft weld plate (EF115)
48	21010048	1	Jack shaft weld plate (EF125)
49	21010049	1	Jack shaft weld plate (EF135)
50	21010050	1	Jack shaft weld plate (EF145)
51	21010051	1	Jack shaft weld plate (EF155)
52	21010052	1	Jack shaft weld plate (EF165)
53	21010053	1	Jack shaft weld plate (EF175)
54	21010054	12	Spring Washer M8
55	21010055	1	Side Cover
56	21010056	1	Plain Washer M10
57	21010057	1	Hex Bolt M10 x 1.5 x 25
58	21010058	2	Hex Nut M22
59	21010059	2	Plain Washer M22
60	21010060	2	Lower Hitch Pin
61	21010061	3	Cotter Pin
62	21010062	1	Top Hitch Pin
63	21010063	1	Top Mast
64	21010064	1	Tool Box

65	21010065	6	Hex Nut M10
66	21010066	6	Plain Washer M10
67	21010067	1	PTO Joint Hook
68	21010068	6	Hex Bolt M10 x 1.5 x 25
69	21010069	1	Top Mast Complete
70	21010070	1	Flap Set (EF85)
71	21010071	1	Flap set (EF95)
72	21010072	1	Flap set (EF105)
73	21010073	1	Flap Set (EF115)
74	21010074	1	Flap set (EF125)
75	21010075	1	Flap set (EF135)
76	21010076	1	Flap set (EF145)
77	21010077	1	Flap set (EF155)
78	21010078	1	Flap set (EF165)
79	21010079	1	Flap set (EF175)
80	21010080	1	Flap Rod (EF85)
81	21010081	1	Flap Rod (EF95)
82	21010082	1	Flap Rod (EF105)
83	21010083	1	Flap Rod (EF115)
84	21010084	1	Flap Rod (EF125)
85	21010085	1	Flap Rod (EF135)
86	21010086	1	Flap Rod (EF145)
87	21010087	1	Flap Rod (EF155)
88	21010088	1	Flap Rod (EF165)
89	21010089	1	Flap Rod (EF175)
90	21010090	6	Plain Washer M8
91	21010091	6	Hex Bolt M8 x 1.25 x 25
92	21010092	1	Hex Bolt M10 x 1.5 x 25
93	21010093	1	Jack shaft weldment support
94	21010094	2	Plain Washer M10
95	21010095	2	Hex Nut M10
96	21010096	4	Hex Bolt M10 x 1.5 x 25
97	21010097	4	Plain Washer M10
98	21010098	4	Hex Nut M10
99	21010099	1	Hex Bolt M10 x 1.5 x 25
100	21010100	1	Hex Bolt M10 x 1.5 x 25
101	21010101	1	Plain Washer M10
102	21010102	1	Plastic Cover
103	21010103	2	Pedestal

FLAIL MOWER MAIN ASSEMBLY (EFG SERIES)

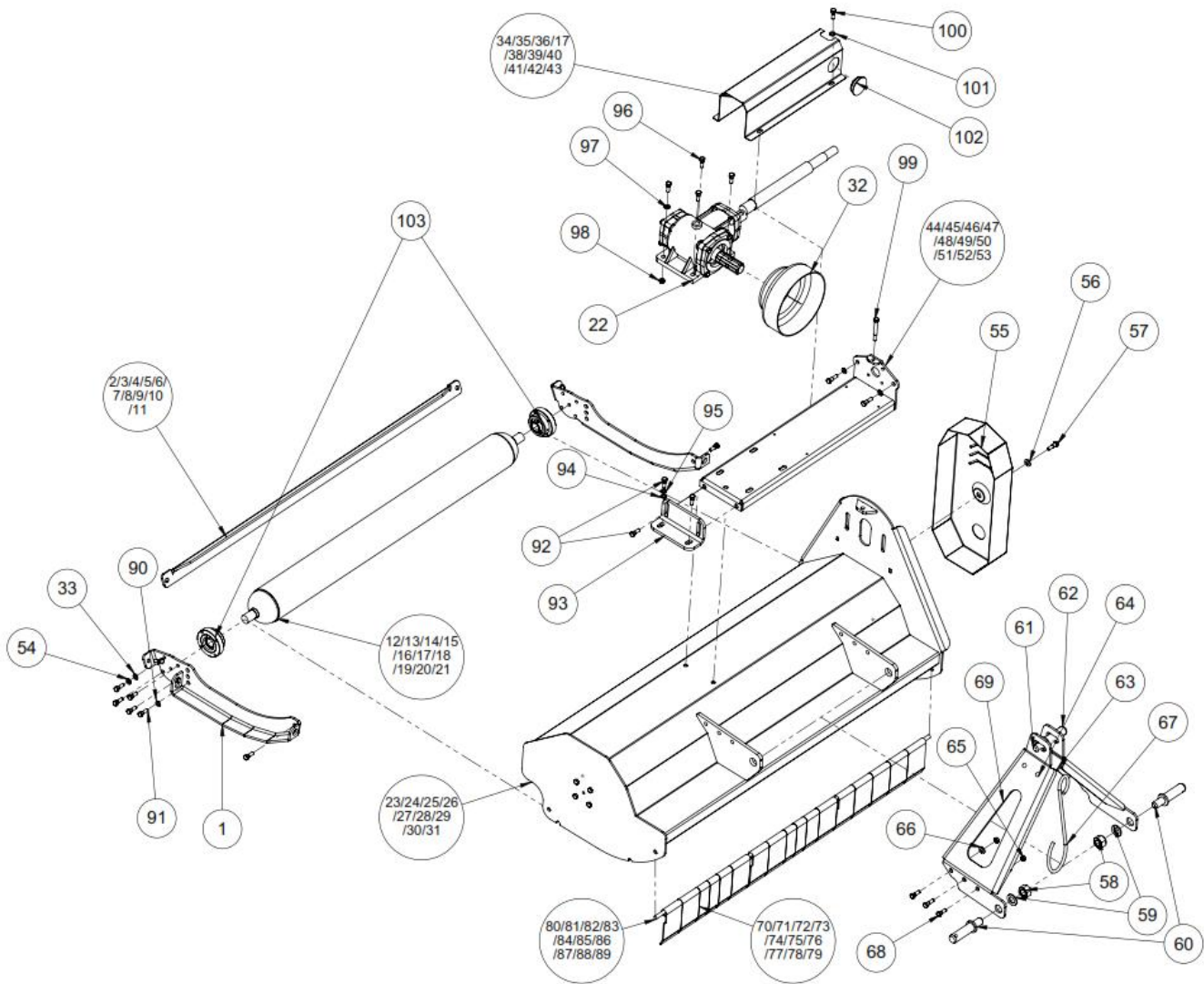

Item	Part Number	Qty	Part Name
1	22010001	6	Hex Bolt M8 x 1.25 x 25
2	22010002	1	Scraper (EFG85)
3	22010003	1	Scraper (EFG95)
4	22010004	1	Scraper (EFG105)
5	22010005	1	Scraper (EFG115)
6	22010006	1	Scraper (EFG125)
7	22010007	1	Scraper (EFG135)
8	22010008	1	Scraper (EFG145)
9	22010009	1	Scraper (EFG155)
10	22010010	1	Scraper (EFG165)
11	22010011	1	Scraper (EFG175)
12	22010012	1	Scraper (EFG195)

13	22010013	1	Back roller (EFG85)
14	22010014	1	Back Roller (EFG95)
15	22010015	1	Back Roller (EFG105)
16	22010016	1	Back Roller (EFG115)
17	22010017	1	Back Roller (EFG125)
18	22010018	1	Back Roller (EFG135)
19	22010019	1	Back Roller (EFG145)
20	22010020	1	Back Roller (EFG155)
21	22010021	1	Back Roller (EFG165)
22	22010022	1	Back Roller (EFG175)
23	22010023	1	Back Roller (EFG195)
24	22010024	1	Gear Box Housing Complete (Without Jackshaft)
25	22010025	1	Main Frame (EFG85)
26	22010026	1	Main Frame (EFG95)
27	22010027	1	Main Frame (EFG105)
28	22010028	1	Main Frame (EFG115)
29	22010029	1	Main Frame (EFG125)
30	22010030	1	Main Frame (EFG135)
31	22010031	1	Main Frame (EFG145)
32	22010032	1	Main Frame (EFG155)
33	22010033	1	Main Frame (EFG165)
34	22010034	1	Main Frame (EFG175)
35	22010035	1	Main Frame (EFG195)
36	22010036	1	Jack Shaft cover (EFG85)
37	22010037	1	Jack Shaft Cover (EFG95)
38	22010038	1	Jack Shaft cover (EFG105)
39	22010039	1	Jack shaft cover (EFG115)
40	22010040	1	Jack Shaft cover (EFG125)
41	22010041	1	Jack shaft cover (EFG135)
42	22010042	1	Jack shaft cover (EFG145)
43	22010043	1	Jack shaft cover (EFG155)
44	22010044	1	Jack shaft cover (EFG165)
45	22010045	1	Jack shaft cover (EFG175)
46	22010046	1	Jack shaft cover (EFG195)
47	22010047	1	Jack shaft Weld Plate (EFG85)
48	22010048	1	Jack Shaft weld plate (EFG95)
49	22010049	1	Jack Shaft weld plate (EFG105)
50	22010050	1	Jack shaft weld plate (EFG115)
51	22010051	1	Jack shaft weld plate (EFG125)
52	22010052	1	Jack shaft weld plate (EFG135)
53	22010053	1	Jack shaft weld plate (EFG145)
54	22010054	1	Jack shaft weld plate (EFG155)
55	22010055	1	Jack shaft weld plate (EFG165)
56	22010056	1	Jack shaft weld plate (EFG175)
57	22010057	1	Jack Shaft weld plate (EFG195)
58	22010058	8	Spring Washer
59	22010059	1	Side Cover
60	22010060	1	Washer
61	22010061	1	Hex Bolt
62	22010062	2	Hex Nut
63	22010063	2	Plain Washer
64	22010064	2	Lower Hitch Pin

65	22010065	3	Cotter Pin
66	22010066	1	Top Hitch Pin
67	22010067	1	Top Mast
68	22010068	1	Tool Box
69	22010069	6	Hex Nut
70	22010070	12	Plain Washer
71	22010071	1	PTO Joint Hook
72	22010072	6	Hex Bolt
73	22010073	1	Top Mast Complete
74	22010074	1	Flap Set (EFG85)
75	22010075	1	Flap set (EFG95)
76	22010076	1	Flap set (EFG105)
77	22010077	1	Flap Set (EFG115)
78	22010078	1	Flap set (EFG125)
79	22010079	1	Flap set (EFG135)
80	22010080	1	Flap set (EFG145)
81	22010081	1	Flap set (EFG155)
82	22010082	1	Flap set (EFG165)
83	22010083	1	Flap set (EFG175)
84	22010084	1	Flap Set (EFG195)
85	22010085	1	Flap Rod (EFG85)
86	22010086	1	Flap Rod (EFG95)
87	22010087	1	Flap Rod (EFG105)
88	22010088	1	Flap Rod (EFG115)
89	22010089	1	Flap Rod (EFG125)
90	22010090	1	Flap Rod (EFG135)
91	22010091	1	Flap Rod (EFG145)
92	22010092	1	Flap Rod (EFG155)
93	22010093	1	Flap Rod (EFG165)
94	22010094	1	Flap Rod (EFG175)
95	22010095	1	Flap Rod (EFG195)
96	22010096	6	Washer
97	22010097	6	Hex Bolt
98	22010098	1	Hex Bolt
99	22010099	1	Jack shaft weldment support
100	22010100	2	Washer
101	22010101	2	Hex Nut
102	22010102	4	Hex Bolt
103	22010103	4	Plain Washer
104	22010104	4	Hex Nut
105	22010105	1	Hex Bolt
106	22010106	1	Hex Bolt
107	22010107	1	Plain Washer
108	22010108	1	Plastic Cover
109	22010109	2	Pedestal

FLAIL MOWER MAIN ASSEMBLY (FL SERIES)

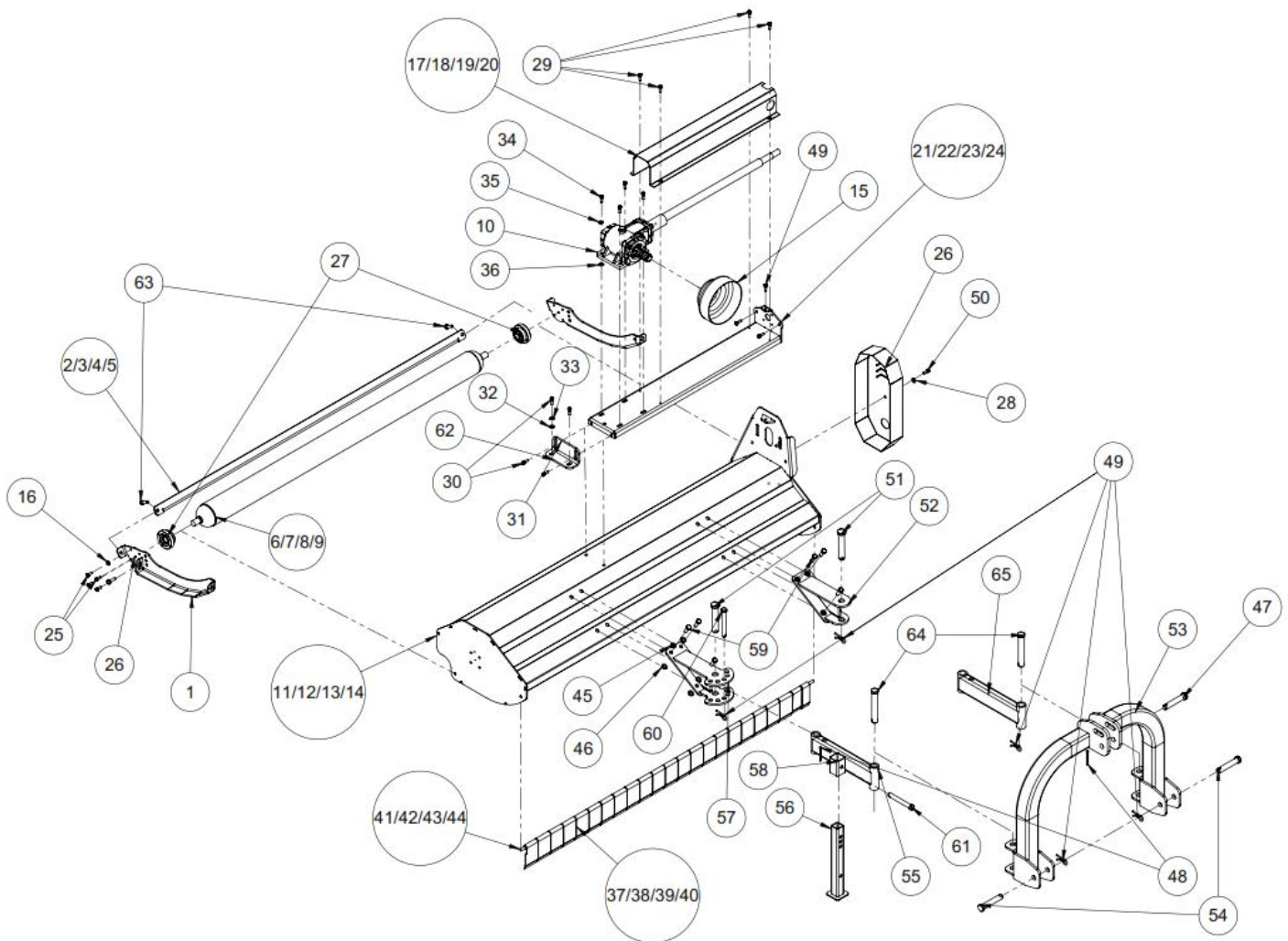

Item	Part Number	Qty	Part Name
1	23010001	6	Hex Bolt M8 x 1.25 x 25
2	23010002	1	Scraper (FL110)
3	23010003	1	Scraper (FL130)
4	23010004	1	Scraper (FL150)
5	23010005	1	Scraper (FL170)
6	23010006	1	Back roller (FL110)
7	23010007	1	Back Roller (FL130)
8	23010008	1	Back Roller (FL150)
9	23010009	1	Back Roller (FL170)
10	23010010	1	Gearbox Housing Complete (Without Jackshaft)
11	23010011	1	Main Frame (FL110)
12	23010012	1	Main Frame (FL130)
13	23010013	1	Main Frame (FL150)
14	23010014	1	Main Frame (FL170)
15	23010015	1	Gear Box PTO Cover
16	23010016	1	Washer

17	23010017	1	Jack Shaft Cover (FL110)
18	23010018	1	Jack Shaft Cover (FL130)
19	23010019	1	Jack Shaft Cover (FL150)
20	23010020	1	Jack Shaft cover (FL180)
21	23010021	1	Jackshaft Weld Plate (FL110)
22	23010022	1	Jackshaft Weld Plate (FL130)
23	23010023	1	Jackshaft Weld Plate (FL150)
24	23010024	1	Jackshaft Weld Plate (FL170)
25	23010025	1	Hex Bolt
26	23010026	1	Depth Skid Plate
27	23010027	1	Pedestal
28	23010028	1	Washer
29	23010029	1	Hex Bolt
30	23010030	1	Hex Bolt
31	23010031	1	Clamp
32	23010032	1	Hex Nut
33	23010033	1	Plain Washer
34	23010034	1	Hex Bolt
35	23010035	1	Plain Washer
36	23010036	1	Hex Nut
37	23010037	1	Flap Set (FL110)
38	23010038	1	Flap Set (FL130)
39	23010039	1	Flap Set (FL150)
40	23010040	1	Flap Set (FL170)
41	23010041	1	Flap Rod (FL110)
42	23010042	1	Flap Rod (FL130)
43	23010043	1	Flap Rod (FL150)
44	23010044	1	Flap Rod (FL170)
45	23010045	1	Spring Washer
46	23010046	1	Hex Nut
47	23010047	1	Top Hitch Pin
48	23010048	1	Cottar Pin
49	23010049	1	R Pin
50	23010050	1	Hex Bolt
51	23010051	1	Pin
52	23010052	1	Hitch Hook Weldment
53	23010053	1	Top Mast Hitch
54	23010054	12	Bottom Hitch Pin
55	23010055	1	Hitch Weldment
56	23010056	1	Stand
57	23010057	1	Adjustable Hitch Weldment
58	23010058	2	Hitch Hook distance Pipe (RH)
59	23010059	2	Hex Bolt
60	23010060	2	Hitch Hook Pin
61	23010061	3	Stand Pin
62	23010062	1	Plate
63	23010063	2	Hex Bolt
64	23010064	1	Hitch Hook Weldment Pin
65	23010065	6	Hitch Hook Distance Pipe (LH)

GEARBOX ASSEMBLY (EF/EFG/FL/FLP SERIES)

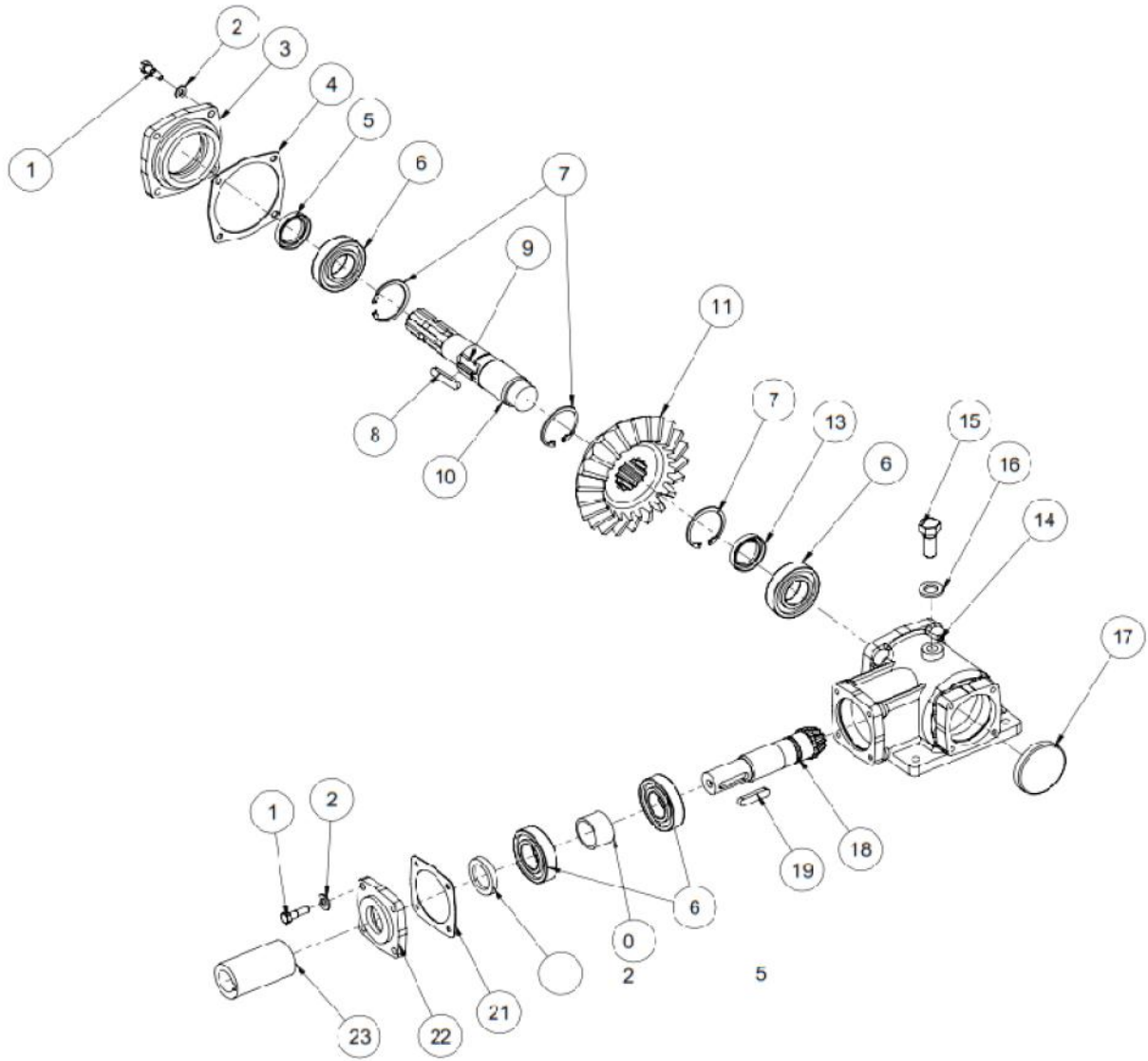

Item	Part Number	Qty	Part Name
1	21020001	20	Hex BoltM10 x 1.5 x 30
2	21020002	20	Plain Washer – 10 mm
3	21020003	1	Side Drive Transmission Cover
4	21020004	1	Side Drive Transmission Cover Gasket
5	21020005	1	Oil Seal
6	21020006	1	Bearing
7	21020007	1	Circlip
8	21020008	3	Input shaft key
9	21020009	6	Shaft key lock spring

10	21020010	1	Input Shaft
11	21020011	1	Crown Pinion
12	21020012	1	Jack Shaft couple
13	21020013	1	Oil seal
14	21020014	1	Gear box housing
15	21020015	1	Oil plug
16	21020016	1	Washer
17	21020017	1	Oil seal
18	21020018	1	Jack Shaft
19	21020019	1	Jack Shaft Key
20	21020020	1	Jack shaft couple
21	21020021	1	Gear box housing gasket (J)
22	21020022	1	Gear box housing cover (J)

BLADE AXLE AND TRANSMISSION PARTS (EF)

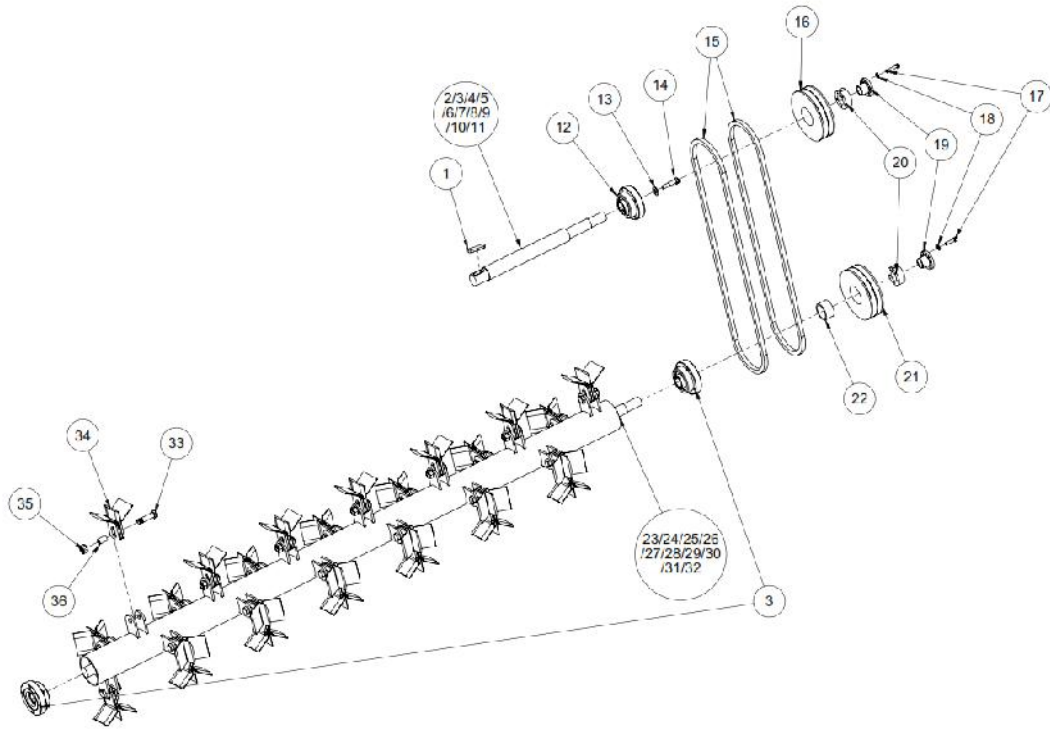

Item	Part Number	Qty	Part Name
1	21030001	1	Jack shaft key
2	21030002	1	Jack shaft (EF85)
3	21030003	1	Jack shaft (EF95)
4	21030004	1	Jack shaft (EF105)
5	21030005	1	Jack shaft (EF115)
6	21030006	1	Jack shaft (EF125)
7	21030007	1	Jack shaft (EF135)
8	21030008	1	Jack shaft (EF145)
9	21030009	1	Jack shaft (EF155)
10	21030010	1	Jack shaft (EF165)
11	21030011	1	Jack shaft (EF175)
	21030037	1	Jack Shaft (EF195)
12	21030012	1	Jack Shaft Pulley
13	21030013	1	Lock spacer
14	21030014	1	Hex Bolt
15	21030015	2	V Belt
16	21030016	1	Jack Shaft Top Pulley
17	21030017	2	Hex Bolt
18	21030018	2	Spring Washer
19	21030019	2	Collate hub tightner
20	21030020	2	Collate hub
21	21030021	1	Bottom Pulley
22	21030022	1	Distance Ring
23	21030023	1	Rotor (Without Blade-EF85)
24	21030024	1	Rotor (Without Blade-EF95)

25	21030025	1	Rotor (without Blade-EF105)
26	21030026	1	Rotor (Without Blade-EF115)
27	21030027	1	Rotor (Without Blade-EF125)
28	21030028	1	Rotor (Without Blade-EF135)
29	21030029	1	Rotor (Without Blade-EF145)
30	21030030	1	Rotor (Without Blade-EF155)
31	21030031	1	Rotor (Without Blade-EF165)
32	21030032	1	Rotor (Without Blade-EF175)
	21030038	1	Rotor (without Blade-EF195)
33	21030033	1	Hex Bolt
34	21030034	1	Y Blade (With Middle Knives)
35	21030035	1	Hex Nut
36	21030036	1	Y Blade Spacer

BLADE AXLE AND TRANSMISSION PARTS (EFG)

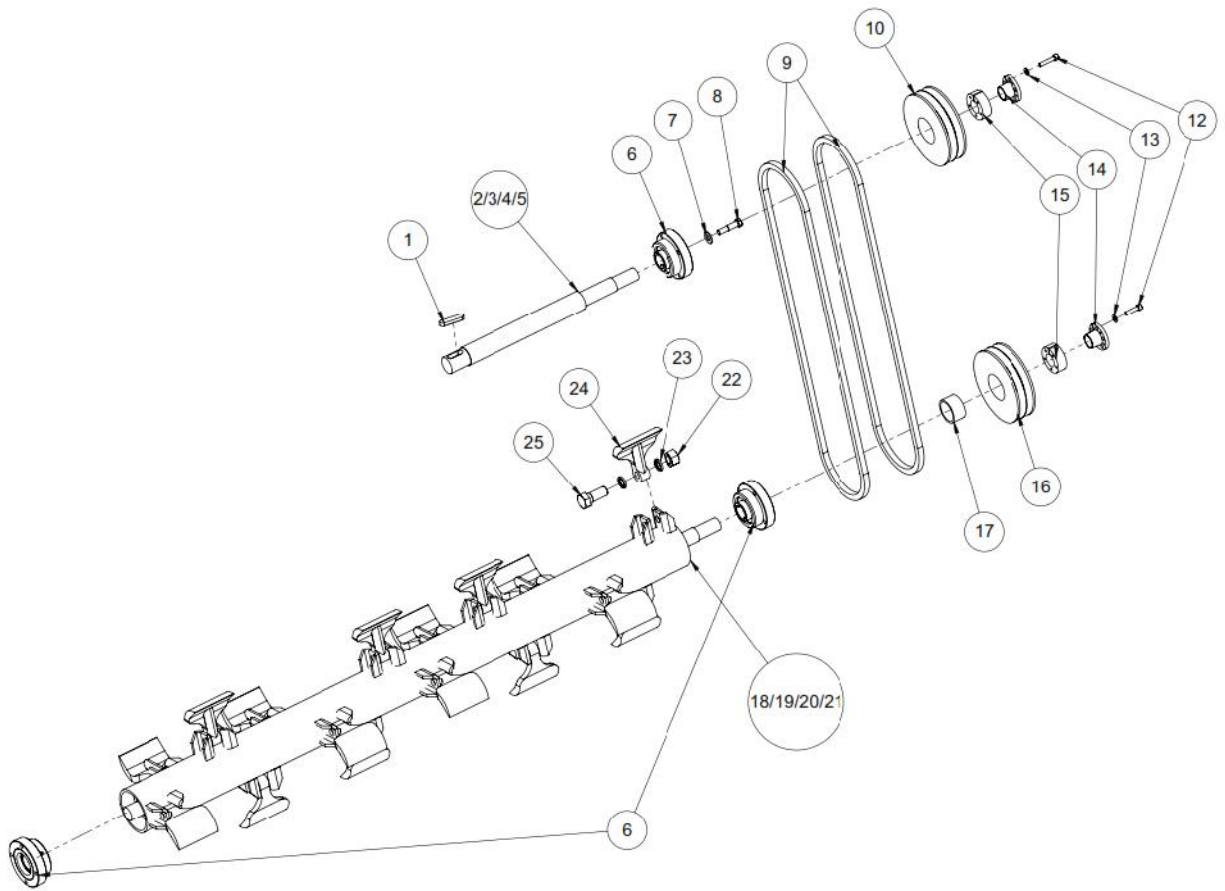

Item	Part Number	Qty	Part Name
1	21030001	1	Jack shaft key
2	21030002	1	Jack shaft (EFG105)
3	21030003	1	Jack shaft (EFG115)
4	21030004	1	Jack shaft (EFG125)
5	21030005	1	Jack shaft (EFG135)
6	21030006	1	Jack shaft (EFG135)
7	21030007	1	Jack shaft (EFG145)
8	21030008	1	Jack shaft (EFG155)
9	21030009	1	Jack shaft (EFG165)
10	21030010	1	Jack shaft (EFG175)
11	21030011	1	Jack shaft (EFG195)
12	21030012	1	Jack Shaft Pulley
13	21030013	1	Lock spacer
14	21030014	1	Hex Bolt
15	21030015	2	V Belt
16	21030016	1	Jack Shaft Top Pulley
17	21030017	2	Hex Bolt
18	21030018	2	Spring Washer

19	21030019	2	Collate hub tightner
20	21030020	2	Collate hub
21	21030021	1	Bottom Pulley
22	21030022	1	Distance Ring
23	21030023	1	Rotor (Without Blade-EFG105)
24	21030024	1	Rotor (Without Blade-EFG115)
25	21030025	1	Rotor (without Blade-EFG125)
26	21030026	1	Rotor (Without Blade-EFG135)
27	21030027	1	Rotor (Without Blade-EFG145)
28	21030028	1	Rotor (Without Blade-EFG155)
29	21030029	1	Rotor (Without Blade-EFG165)
30	21030030	1	Rotor (Without Blade-EFG175)
31	21030031	1	Rotor (Without Blade-EFG195)
33	21030033	1	Hex Bolt
34	21030034	1	Hammer Forged Blades (EFG/FL/FLP)
35	21030035	1	Hex Nut

BLADE AXLE AND TRANSMISSION PARTS (FL/FLP)

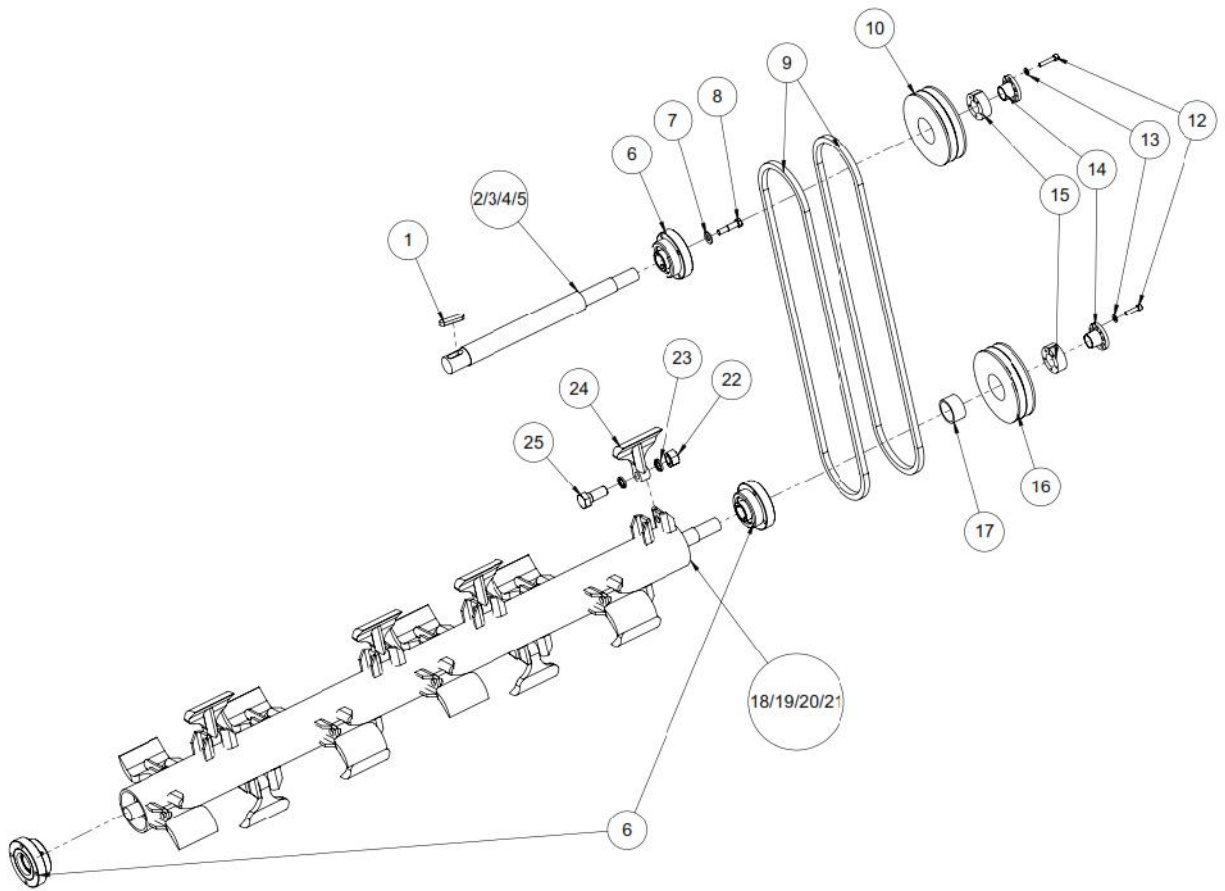

Item	Part Number	Qty	Part Name
1	21030001	1	Jack shaft key
2	21030002	1	Jack shaft (FL110/FLP110)
3	21030003	1	Jack shaft (FL130/FLP130)
4	21030004	1	Jack shaft (FL150/FLP150)
5	21030005	1	Jack shaft (FL170/FLP170)
6	21030012	1	Pedestal
7	21030013	1	Lock spacer
8	21030014	1	Hex Bolt
9	21030015	2	V Belt
10	21030016	1	Jack Shaft Top Pulley
12	21030017	2	Hex Bolt
13	21030018	2	Spring Washer
14	21030019	2	Collate hub tightner
15	21030020	2	Collate hub
16	21030021	1	Bottom Pulley
17	21030022	1	Distance Ring
18	21030023	1	Rotor (FL110/FLP110)
19	21030024	1	Rotor (FL130/FLP130)

20	21030025	1	Rotor (FL150/FLP150)
21	21030026	1	Rotor (FL170/FLP170)
22	21030033	1	Hex Nut
23	21030034	2	Washer
24	21030035	1	Hammer Forged Blades (EFG/FL/FLP)
25	21030036	1	Hex Bolt

SECTION – 10 WARRANTY

GANESH AGRO EQUIPMENTS warrants to the original purchaser that this product will be free from defects in material and workmanship beginning on the date of purchase by the end user according to the following schedule when used as intended and under normal service and conditions for personal use.

Overall Unit and Driveline: 2 year Parts

PTO Joint : Warranty Not applicable (Except Manufacturing defect)

Blade: Warranty Not applicable (Except Manufacturing Defect)

Paint : Warranty Not applicable (Except Manufacturing Defect)

Gearbox: 2 years Parts

This Warranty is limited to the replacement of any defective part by GANESH AGRO EQUIPMENTS and the installation by the dealer of any such replacement part, and does not cover common wear items. GANESH AGRO EQUIPMENTS reserves the right to inspect any equipment or parts which are claimed to have been defective in material or workmanship.

This Warranty does not apply to any part or product which in GANESH AGRO EQUIPMENT'S judgment shall have been misused or damaged by accident or lack of normal maintenance or care, or which has been repaired or altered in a way which adversely affects its performance or reliability, or which has been used for a purpose for which the product is not designed. Misuse also specifically includes failure to properly maintain oil levels, grease points, and driveline shafts. Claims under this Warranty should be made to the dealer/company which originally sold the product and all warranty adjustments must be made through an authorized GANESH AGRO EQUIPMENTS'S dealer. GANESH AGRO EQUIPMENTS reserves the right to make changes in materials or design of the product at any time without notice. This Warranty shall not be interpreted to render GANESH AGRO EQUIPMENTS liable for damages of any kind, direct, consequential, or contingent to property. Furthermore, GANESH AGRO EQUIPMENTS shall not be liable for damages resulting from any cause beyond its reasonable control. This Warranty does not extend to loss of crops, any expense or loss for labor, supplies, rental machinery or for any other reason.

No other warranty of any kind whatsoever, express or implied, is made with respect to this sale; and all implied warranties of merchantability and fitness for a particular purpose which exceed the obligations set forth in this written warranty are hereby disclaimed and excluded from this sale. This Warranty is not valid unless end user are not registered with GANESH AGRO EQUIPMENTS within 30 days from the date of purchase by the end user.

Seal & Sign –

Date –

Place - Vadpura